

PLAN DE RACCORDEMENT POUR LA MACHINE A CAFE PRESIDENT GTi 2-gr.
 PUISSANCE 6200-7400 WATT / 3x400 VOLTS

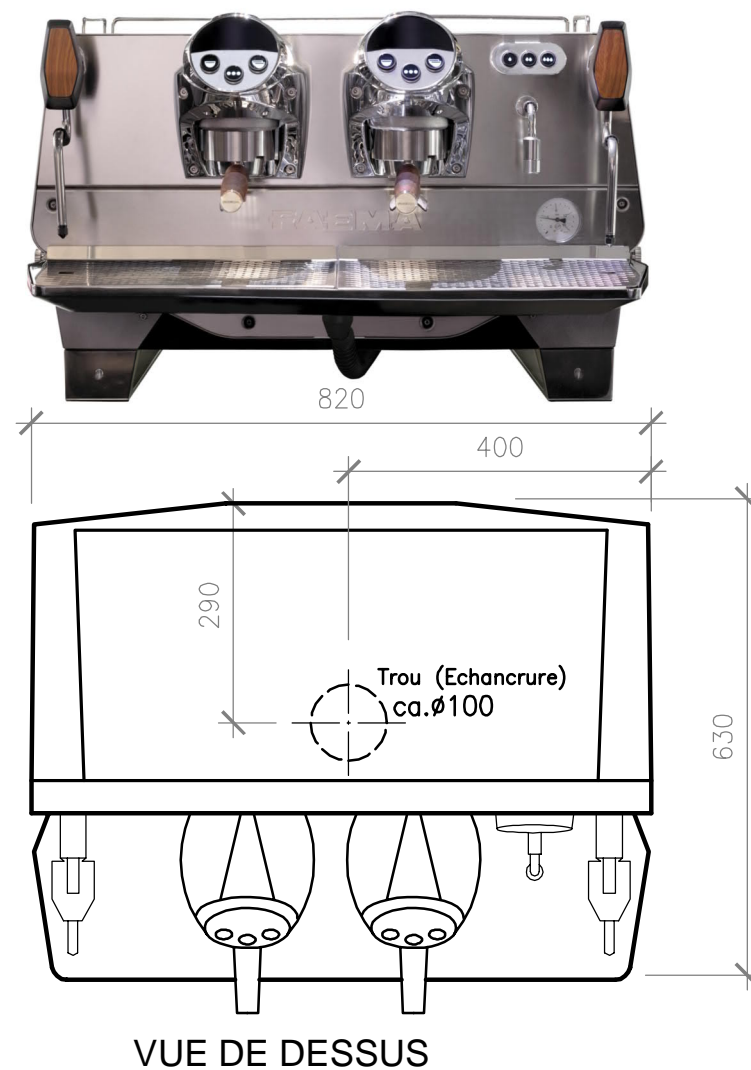

PLAN DE RACCORDEMENT POUR LA MACHINE A CAFE PRESIDENT GTi 3-gr.
 PUISSANCE 7500-8800 WATT / 3x400 VOLTS

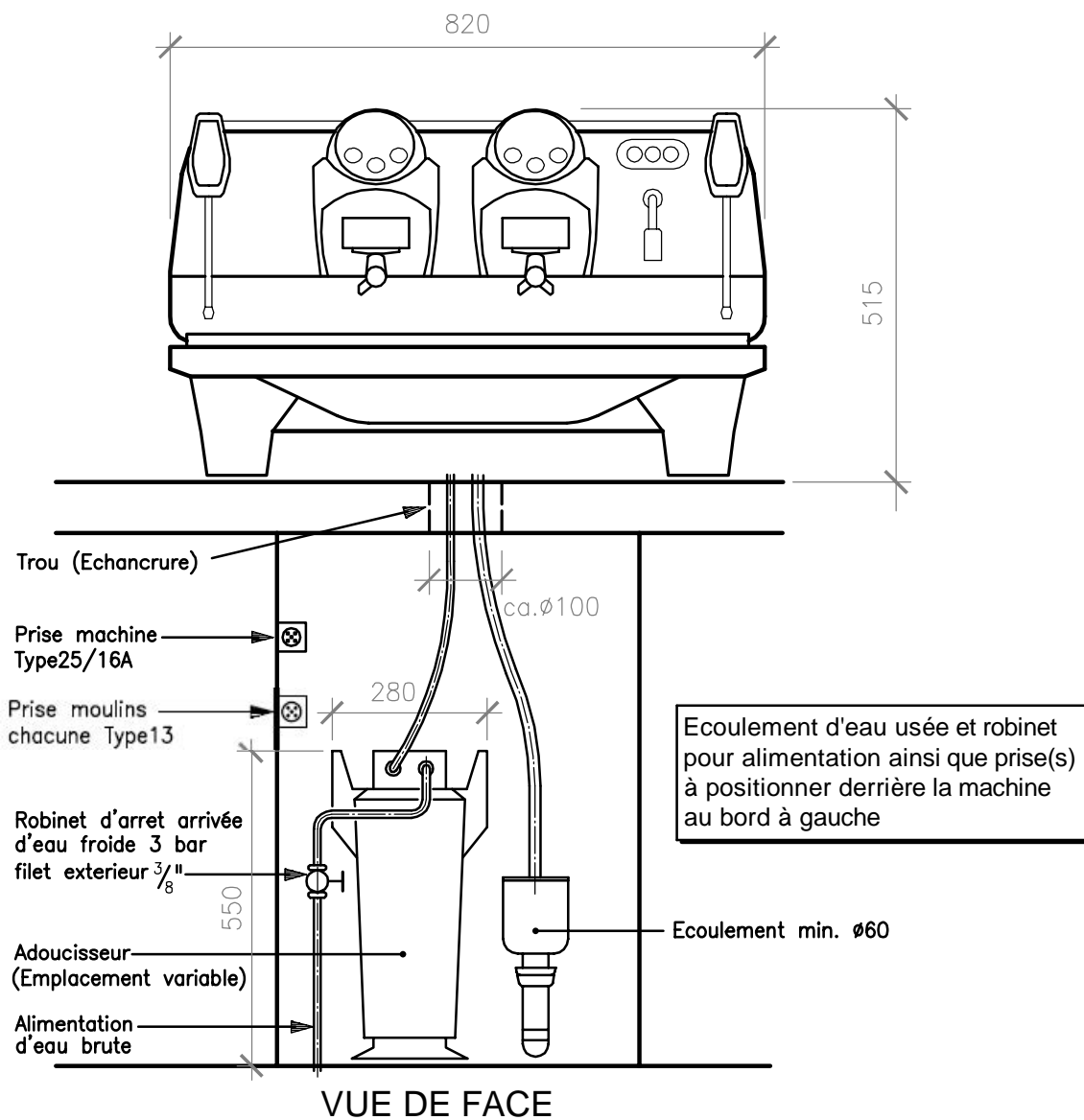