

PLAN DE RACCORDEMENT POUR LA MACHINE A CAFE M200 DT/2 PUISSANCE 6200-7400 WATT / 3x400 VOLTS

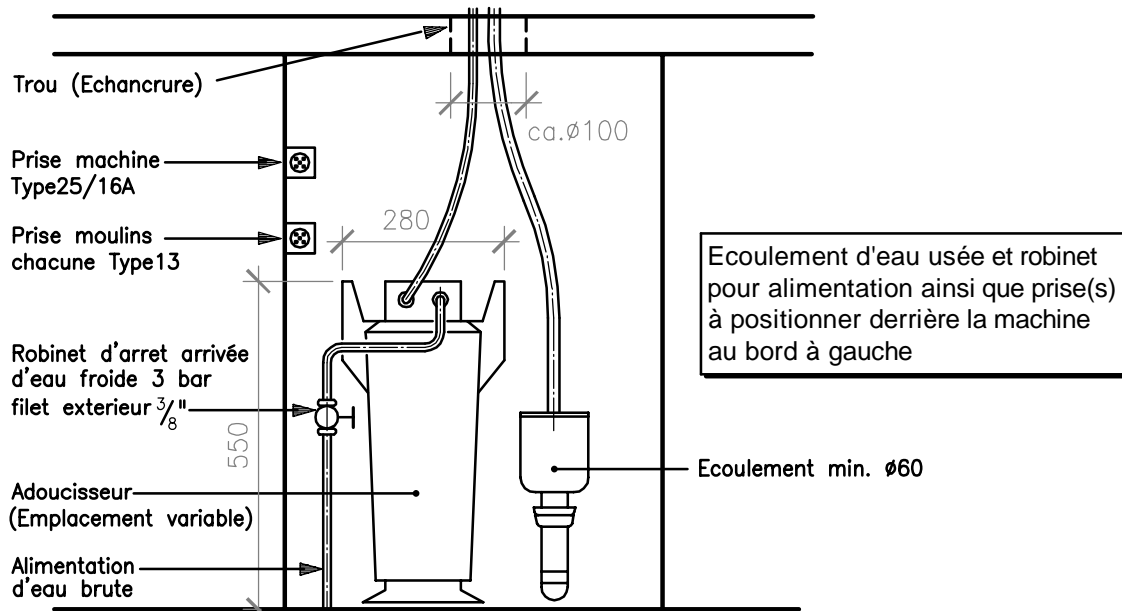
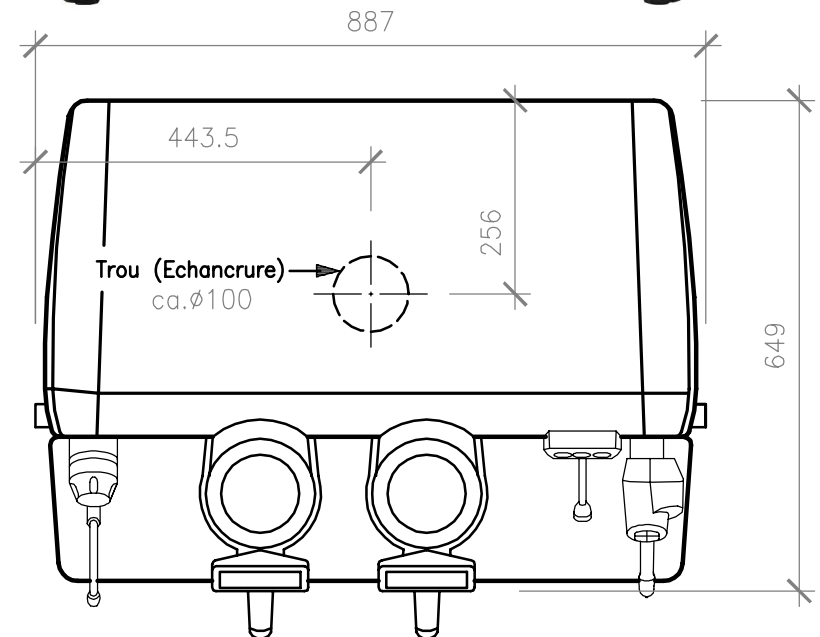
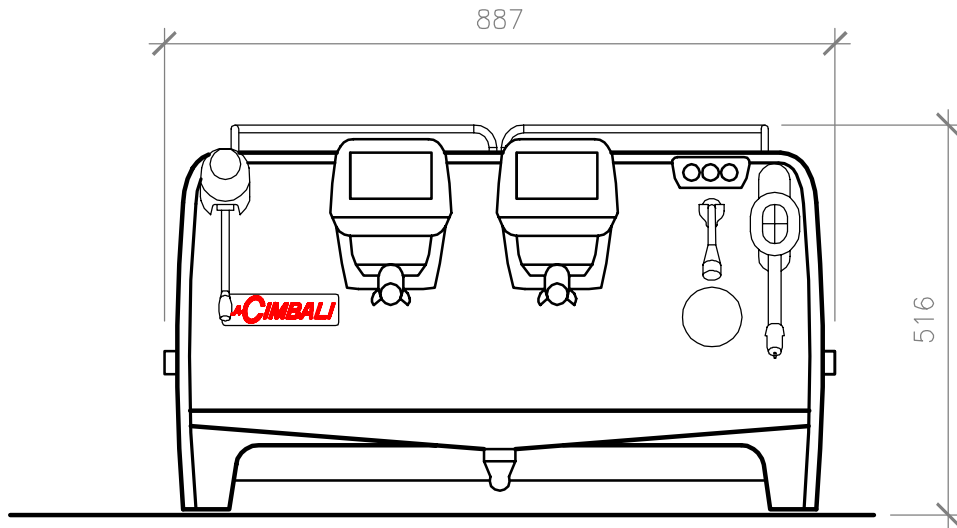

Ecoulement d'eau usée et robinet pour alimentation ainsi que prise(s) à positionner derrière la machine au bord à gauche

VUE DE FACE

VUE DE DESSUS

PLAN DE RACCORDEMENT POUR LA MACHINE A CAFE M200 DT/3
 PUISSANCE 7500-8800 WATT / 3x400 VOLTS

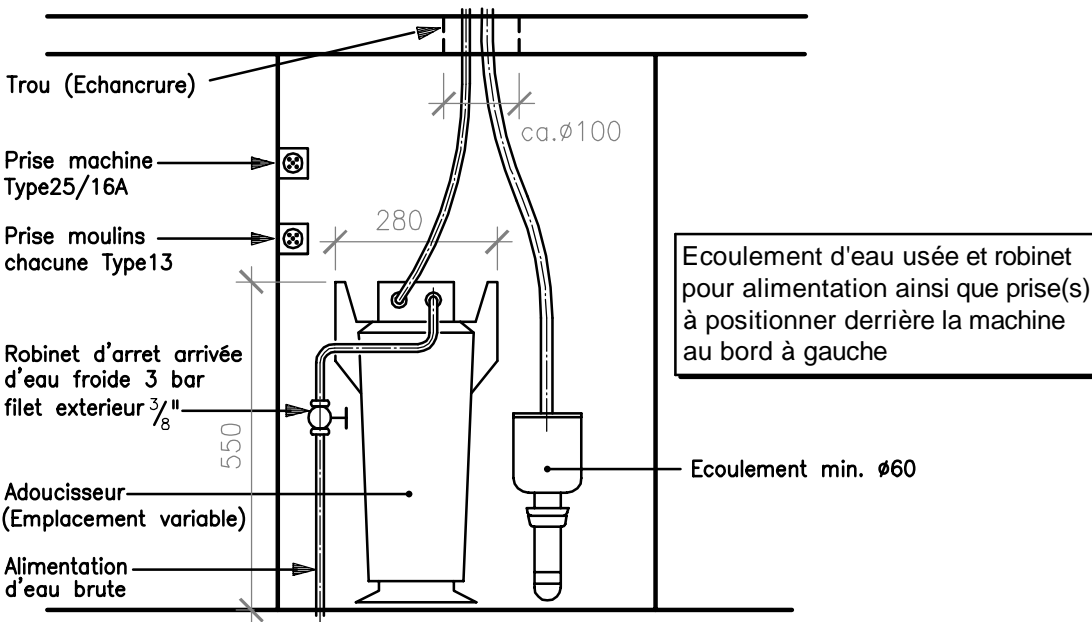
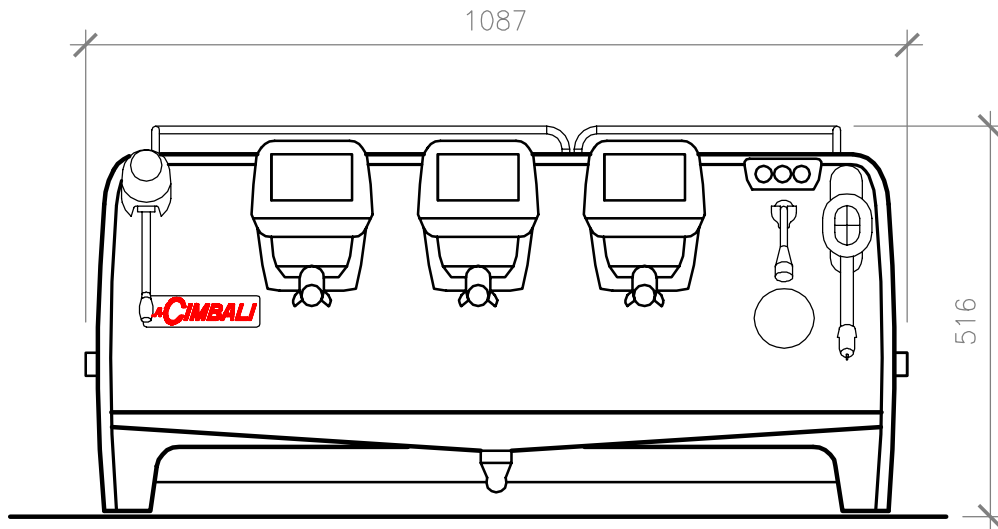

Ecoulement d'eau usée et robinet pour alimentation ainsi que prise(s) à positionner derrière la machine au bord à gauche

VUE DE FACE

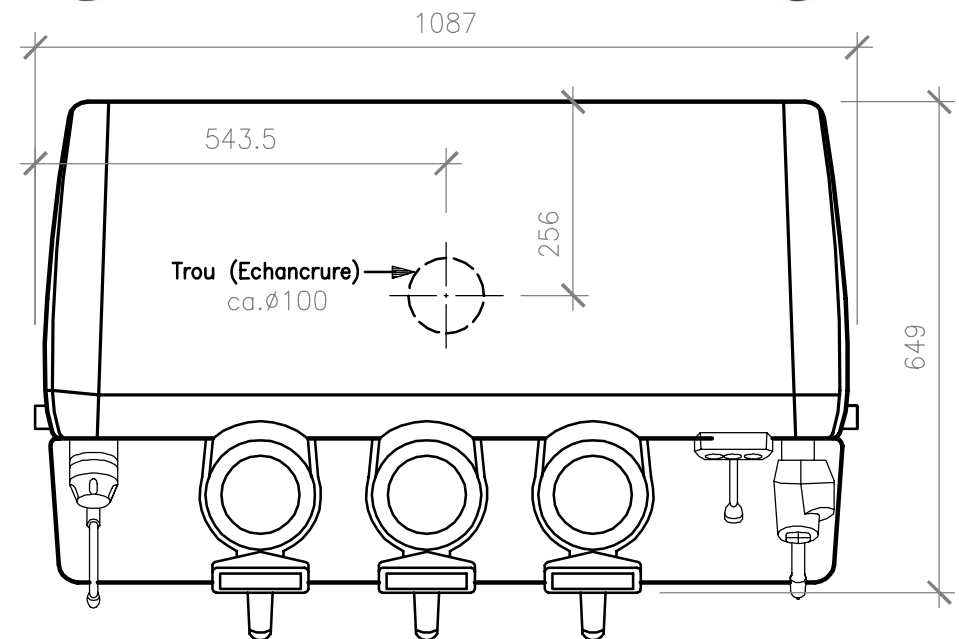

VUE DE DESSUS

PLAN DE RACCORDEMENT POUR LA MACHINE A CAFE M200 DT/4 PUISSANCE 8800-10400 WATT / 3x400 VOLTS

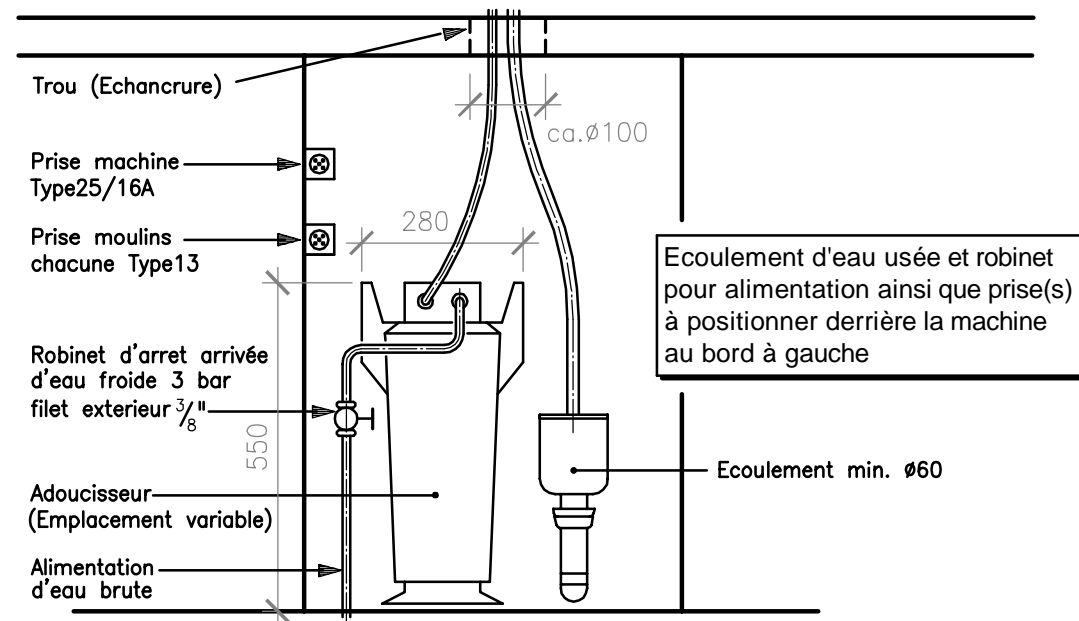
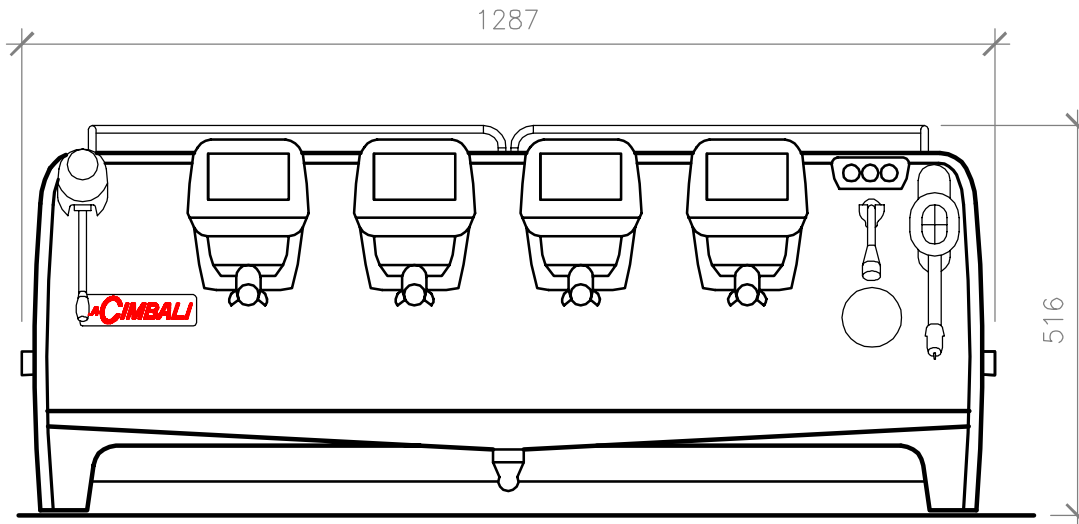

VUE DE FACE

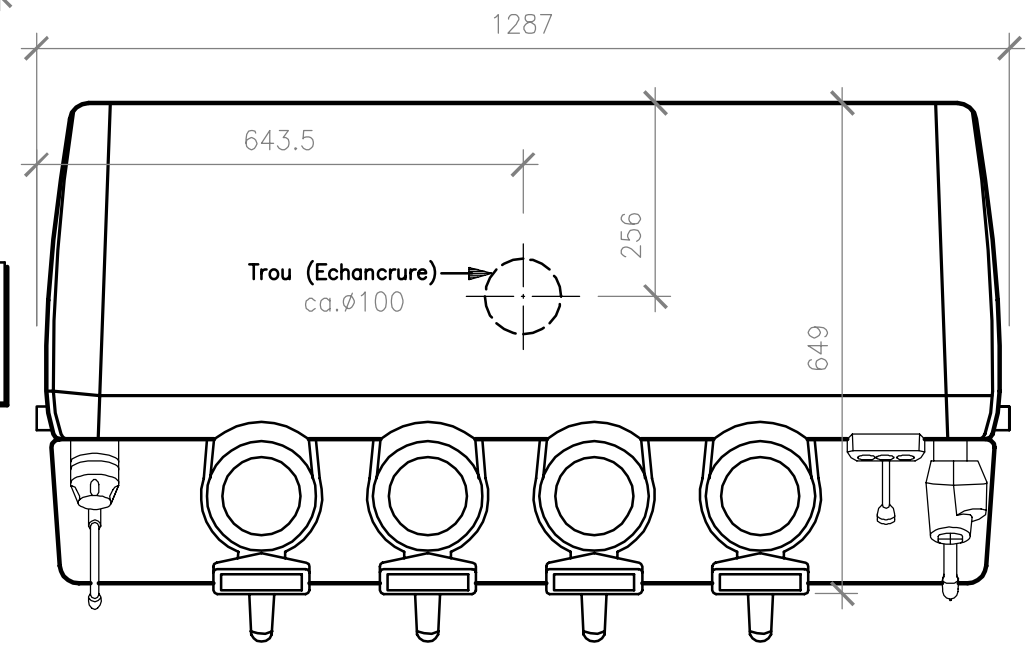

VUE DE DESSUS